

Reciprocating Pumps

HEAVY DUTY, HORIZONTAL, SIMPLEX, DUPLEX, TRIPLEX, QUINTUPLEX, API 674 LATEST EDITION

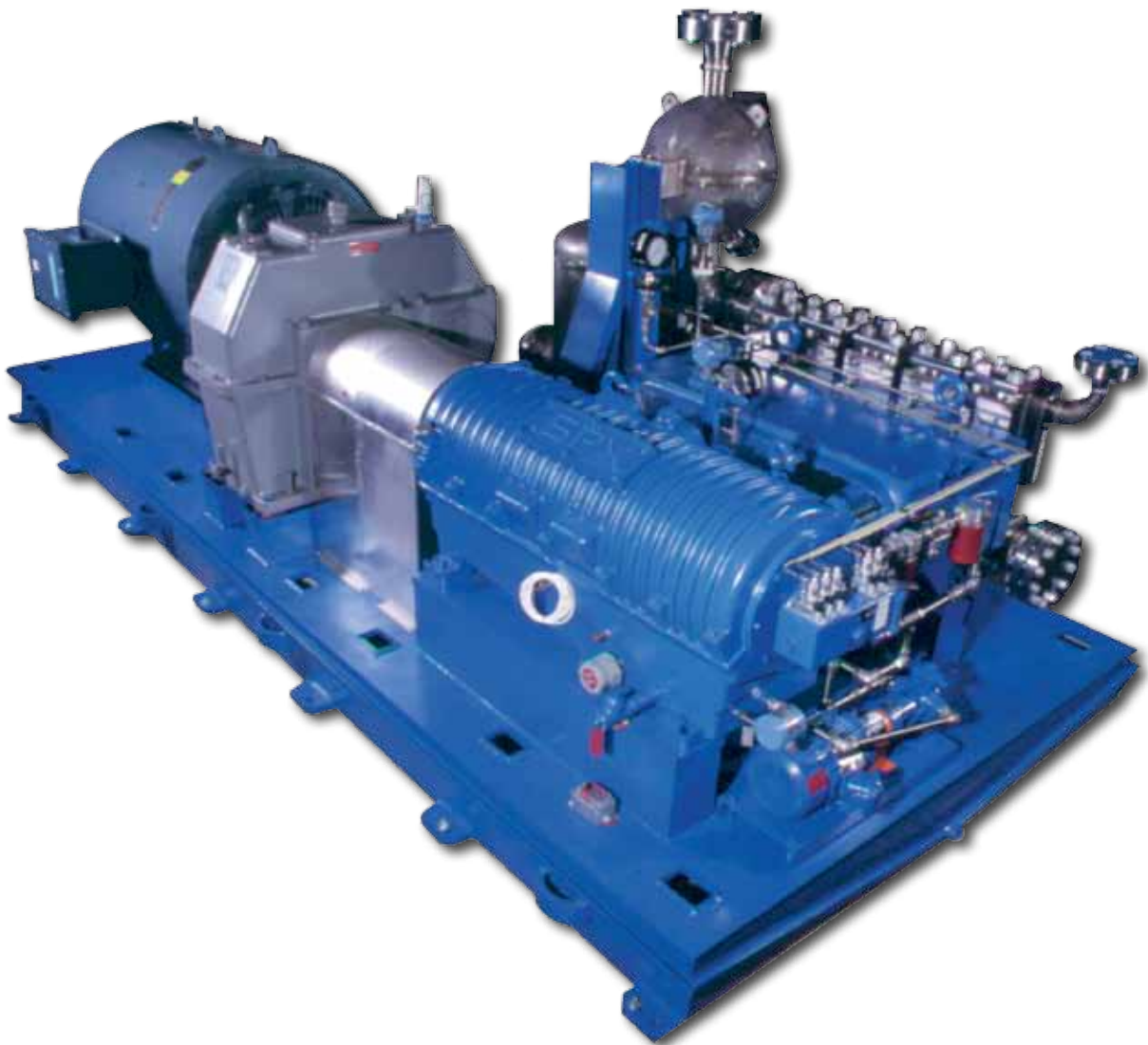



SPX - An introduction

SPX is a Fortune 500 multi-industry manufacturing leader, headquartered in Charlotte, North Carolina. SPX manufactures and markets products, components, services and technologies that are integral to meeting today's challenges and tomorrow's needs. We are a place where innovation is fostered, and the real needs of business are understood. We transform ideas into powerful solutions to help our customers meet their goals, overcome business challenges and thrive in a complex, always changing marketplace.

SPX's Flow Technology segment designs, manufactures and markets engineering solutions and products used to process, blend, meter and transport fluids. We also offer equipment for air and gas filtration and dehydration. Our leading brands have global operations which service the food + beverage, power + energy, and industrial processes.



CLYDEUNION PUMPS, AN SPX BRAND - GENERATIONS OF EXPERIENCE

Whilst the name is relatively new, the ClydeUnion Pumps brand is known worldwide for supplying reliable and robust engineered pumping solutions stemming from over 140 years of industry expertise. Our experience spans across several complex industries including oil and gas, nuclear and conventional power generation, desalination and other key markets relevant to our product portfolio.

› ClydeUnion Pumps



Weir Pumps - Clyde Pumps - Mather & Platt -
Drysdale - WH Allen - Girdlestone -
Allen Gwynnes - Harland



Union Pump - David Brown Pumps
DB Guinard Pumps - American Pump - Pumpline



› ClydeUnion Pumps



High technology pumps for the most demanding services

ClydeUnion Pumps, an SPX Brand, specialises in the design and manufacture of API 674 reciprocating pumps and pumping packages. At ClydeUnion Pumps you will find a commitment to quality throughout the company. Our Quality Management System is fully approved to ISO 9001:2008 and independently verified to comply with the latest quality standards. ClydeUnion Pumps has a worldwide reputation for providing optimised reliability in the most severe duty applications.

SEAWATER REVERSE OSMOSIS

Worldwide demand for clean water continues to increase. With very high efficiency and reliability, our reciprocating power pumps are ideally suited for seawater reverse osmosis. ClydeUnion Pumps reciprocating pumps, combined with energy recovery systems, provide the industry's most efficient solution for your high pressure reverse osmosis pumping needs. They also offer the added benefit of delivering filtered seawater at constant flow to the membranes at varying system pressures.

GENERAL INDUSTRY

At ClydeUnion Pumps we have supplied reciprocating power pumps for a wide range of industrial services including high pressure water blasting, cleaning and cutting, metals descale, mine dewatering, hydraulic charge, hydrostatic test, chemical processing and high pressure mixing. The experience gained in these segments enable us to offer our customers engineered products tailored to their specific requirements.

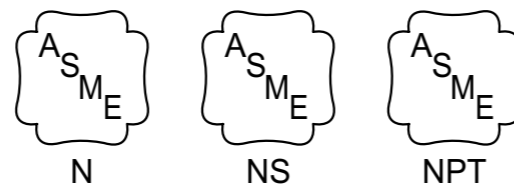

OIL + GAS PRODUCTION

Our pumps can be found operating wherever there are oil fields, both onshore and offshore. High efficiency and reliability are major benefits of ClydeUnion Pumps equipment - both of which are vital considerations in the oil and gas industry. Pumps have been supplied to satisfy a wide range of pumping services including: high pressure seawater injection and disposal, methanol injection, blowout preventer charge pumps, subsea hydraulic systems, gas processing systems for dehydration and gas sweetening. ClydeUnion Pumps reciprocating pumps are designed to handle all types of industry related fluids.

REFINERIES

Today's complex refinery processes demand specialised pumping solutions. Extremes of temperature, high-pressure and the ability to handle volatile fluids, calls for highly engineered pumps that can perform reliably in such arduous conditions. ClydeUnion Pumps has many years of worldwide experience in the supply of special reciprocating pumps to the refinery industry and for nuclear applications, and is committed to providing its customers with solutions for the most complex of pumping requirements.

Reciprocating pumps - Heavy duty horizontal pumps

ClydeUnion Pumps reciprocating power pumps are designed with exceptional versatility to efficiently meet the requirements of a wide variety of pumping applications. They are ruggedly designed for minimum maintenance and to meet the heavy-duty requirements of continuous operation in general industry, as well as API 674 services.

These units are driven via electric motors or diesel engines through V-belt or gear reducers. Stuffing boxes are specifically designed for applications to maximise packing life and minimise maintenance. Equipment can be packaged to meet the most stringent requirements of API 674.

There are thousands of ClydeUnion Pumps reciprocating power pumps operating worldwide on services as diverse as:

- HVGO high temperature charge at 426°C (800°F) and at 4,500 psig (310 barg) discharge pressure complex engineered system
- High pressure pumps for Hydro-demolition: 20,000 psig (1,380 barg)
- High pressure carbamate and ammonia pumps for fertiliser service
- High pressure salt water or produced injection - high salinity, high pressure with sand, oil and H₂S

PROVEN PRODUCT INTEGRITY

The ClydeUnion Pumps reciprocating power pump encompasses a proven design history for excellence in reliability. ClydeUnion Pumps simplex, duplex, triplex and quintuplex pumps all have an enviable history of sound engineering, designed to exceed the rigorous requirements of API 674 and customer satisfaction.

EASE OF MAINTENANCE

The simple modular construction of the reciprocating power pump offers ease of maintenance and reliability. A complete fluid end change-out can be completed in under eight hours. Routine packing, plunger and valve assembly changes are made easily by the user without the need for factory assistance.

PUMPSETS + PACKAGES

ClydeUnion Pumps has extensive experience in providing complex pumpsets including electric motors, gearboxes, special auxiliary lube oil systems, steam turbines, diesel engines, control panels and instrumentation.



Reciprocating pump - Features

1 FLUID CYLINDER

- All API 674 material options
- Pressure integrity designed to ASME VIII and API 674 latest edition

2 DISCHARGE MANIFOLD

- Reversible end-to-end
- ANSI B16.5 standard flanges
- All API 674 material options
- NPT + Grayloc connections available

3 LIQUID END BOLTING

- High strength alloy steel standard
- Stainless steel options available

4 SUCTION MANIFOLD

- Reversible end-to-end
- All API 674 material options
- ANSI B16.5 standard flanges
- NPT + Grayloc connections available

5 SUCTION VALVE ASSEMBLY

- Valve assemblies clamped between manifold and fluid cylinder. Some models have pressed valve seats
- Disc valves standard - low to medium pressure
- Wing guided bevel valves - high pressure
- Abrasion resistant and ball valves for slurry
- Light and heavy rate springs available for special requirements (NPSH)

6 DISCHARGE VALVE ASSEMBLY

- Valve assemblies clamped between manifold and fluid cylinder. Some models have pressed valve seats
- Disc valves standard - low to medium pressure
- Wing guided bevel valves - high pressure
- Abrasion resistant and ball valves for slurry
- Light and heavy rate springs available for special requirements (NPSH)

7 STUFFING BOX ASSEMBLY

- All API 674 material options
- Standard self-adjusting spring loaded
- Adjustable stuffing box for more critical services
- Special leakage control (UNI-LOK®) with detection system
- UNI-LOK® Zero for volatile and toxic liquids

8 STUFFING BOX SPRING

- To provide automatic adjustment as packing wears

9 PACKING

- Square aramid fibre/telfon standard
- Special V-ring design for high pressure applications in various materials

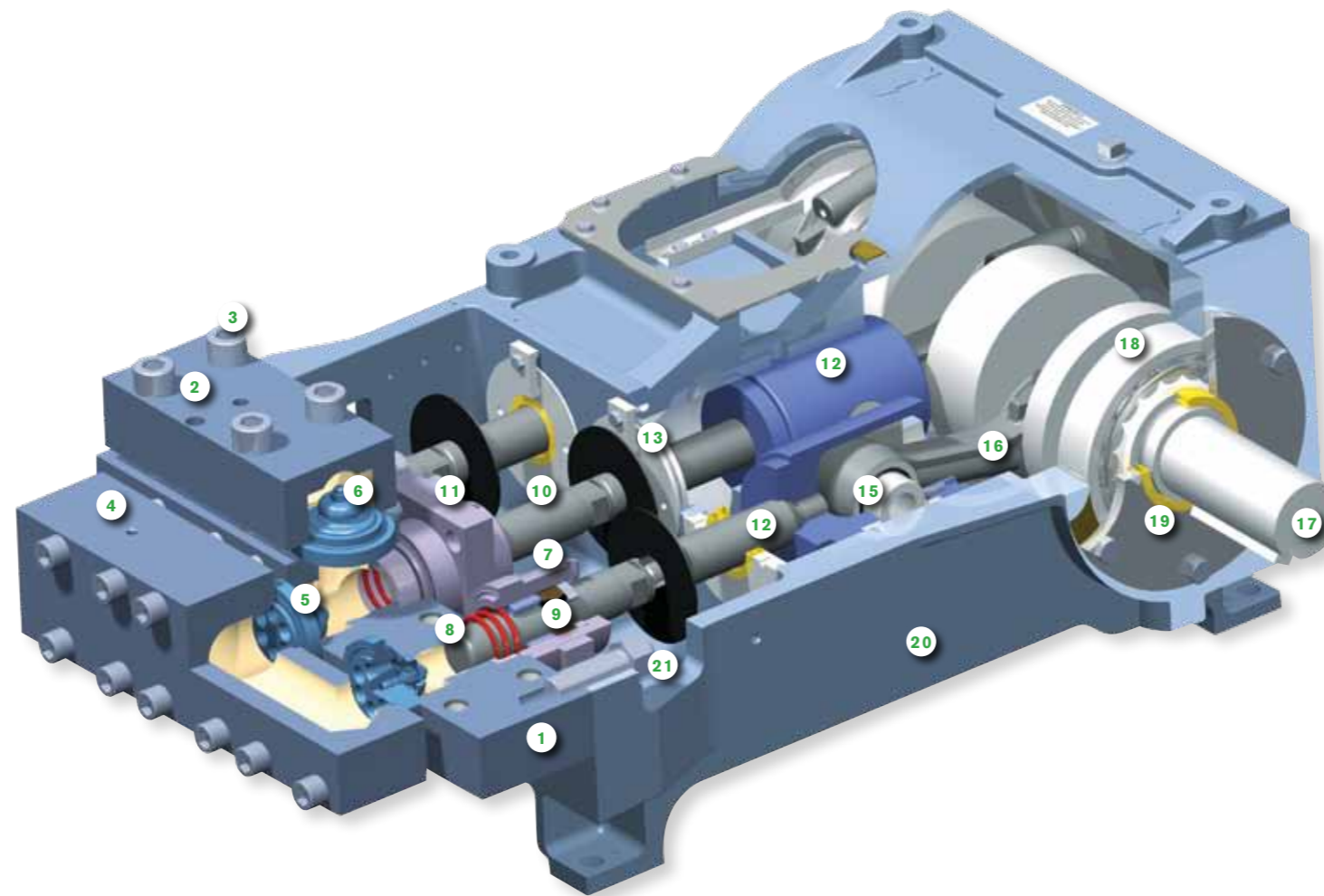

10 PLUNGER

- Various coatings available - thermal spray and rod welding processes
- Severe duties require special plunger hardness for optimum reliability

11 STUFFING BOX FLANGE

- Designed to maintain stuffing box position

12 CROSSHEAD EXTENSION

- Provides accurate alignment between plunger and crosshead
- Offered in 12% - 13% chrome for corrosion and wear resistance

13 CROSSHEAD STUB SEAL

- Most models use spring loaded lip type elastomer seals. Others use square packing
- Higher power models available with replaceable shoes

14 CROSSHEAD

- Large diameter, full piston type for optimum support
- Cast iron operating against cast iron bores for excellent bearing surface

15 WRIST PINS + BEARING

- Hardened steel pin operating against a sintered bronze bushing

16 CONNECTING ROD + BEARING ASSEMBLY

- Heavy duty ductile iron or steel rods with separate bolted caps
- Connecting rod bearings are split, replaceable, precision type babbitt lined steel

17 CRANKSHAFT

- One-piece SAE 4140 steel for toughness and high endurance limit
- Reversible in power frame for drive input from either side of pump for most models

18 CRANKSHAFT MAIN BEARINGS

- Two anti-friction taper roller bearings designed for 3 year L10 life
- Several of our larger models use spherical roller bearings

19 CRANKSHAFT OIL SEAL

- Spring loaded lip type elastomer seals

20 POWER FRAME

- A48 Class 30 cast iron rugged construction and easy full maintenance
- Full cylindrical crosshead bores - can be fitted with liners when required
- Available with gear packs with several ratios for most models
- Additional drive methods include self standing gears and V-belts

21 TOP MOUNT MOTOR MOUNT

- For most models the power frame is suitable for top mounting motor for V-belt drive



FIELD TRIAL SUCCESS

Enterprise Products:

Port Allen Facility, Louisiana, USA

The challenge was to combat short packing life and high volatile organic compound emissions on a butane service, CUP-TD60 reciprocating pump

Following the installation of: UNI-LOK® ZERO SEALING SYSTEMS

emissions are now 33% of EPA allowable limits and packing life was extended by a factor of 4

"Enterprise Products is very pleased with the sealing arrangement ClydeUnion Pumps has developed. It has virtually resolved a recurring fugitive emissions issue that has always plagued positive displacement pumps in light hydrocarbon service"

The CP advantage is now available in reciprocating pumps



Sealing technology for the 21st century

UNI-LOK® ZERO SEALING SYSTEM

Developed to control leakage of volatile organic compounds (VOCs) to the atmosphere, the UNI-LOK® Zero provides a simple means of pressuring the stuffing box to 20 to 40 psi (1.4 to 2.8 Bar) above the peak discharge pump pressure. This eliminates any migration of pumpage past the primary seal of the stuffing box and into the atmosphere (similar to an API 682 Plan 53C)

THE SYSTEM COMPRISES 3 MAIN COMPONENTS:

- A device that references only peak discharge pressure from the discharge line of the pump
- A patented CP barrier fluid reservoir that takes peak discharge reference pressure and adds 20 to 40 psi (1.4 to 2.8 bar) to the barrier fluid that is injected into the stuffing box. This is accomplished without the need for external nitrogen gas supplies, external pumps, power supplies or bladder accumulators
- A unique stuffing box designed to accommodate reverse pressure sealing. The barrier fluid injected behind the primary packaging is always 20 to 40 psi (1.4 to 2.8 Bar) above product pressure. Therefore, any leakage is barrier fluid into the pump, effectively sealing the pumpage from atmosphere

The UNI-LOK® Zero system is available for both new equipment and as an aftermarket retrofit to provide unparalleled protection from VOC emissions to comply with current and future environmental controls

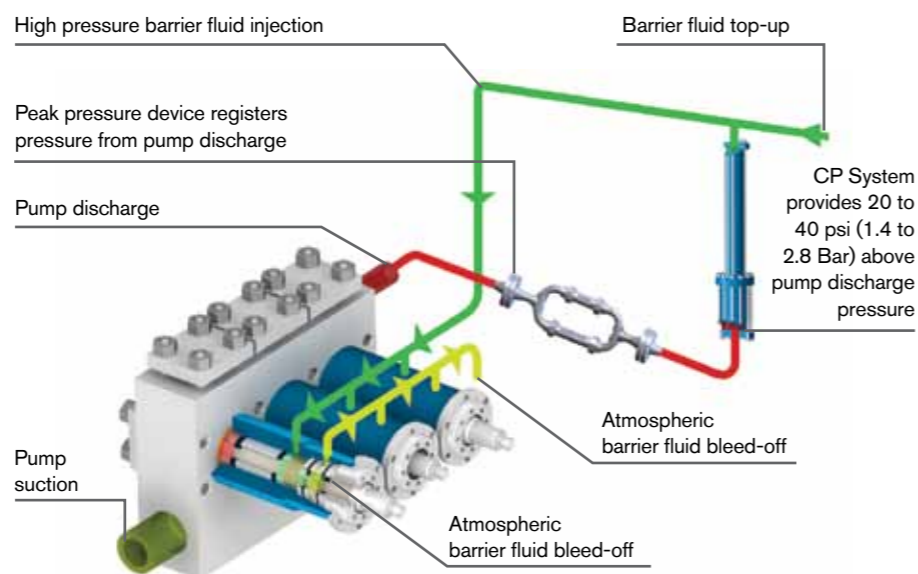

For more information refer to the UNI-LOK® Zero brochure

Standard hydraulic range - coverage chart

50HZ RANGE COVERAGE CHART

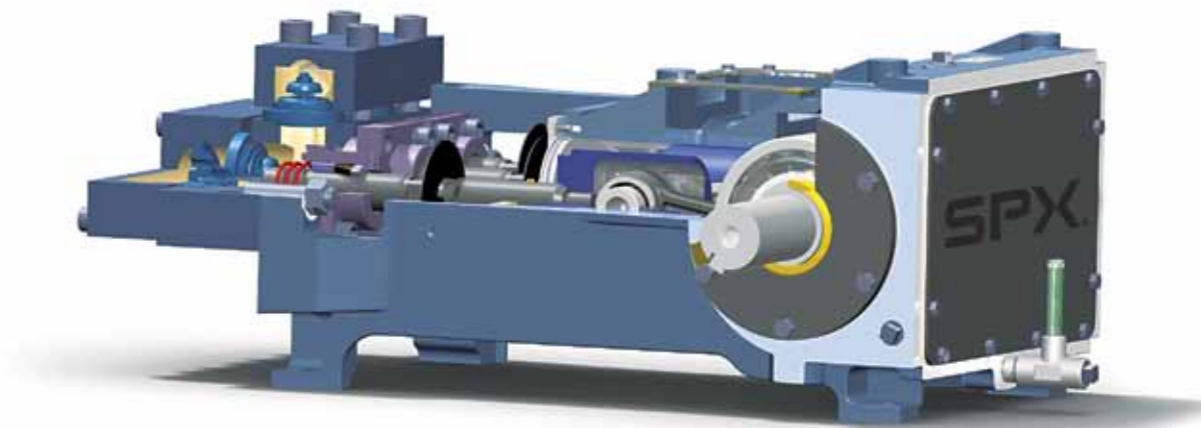
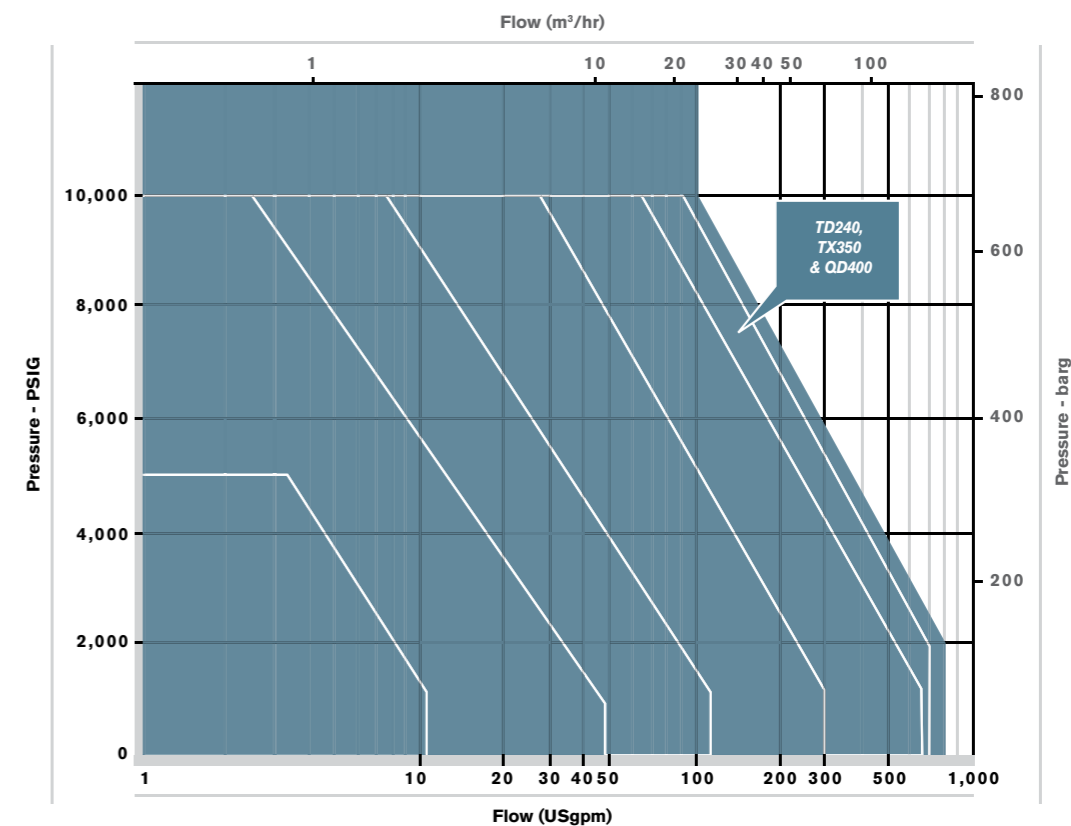

This chart covers the reciprocating pump standard range. Other engineering designs exist for extreme applications



Global aftermarket capability best in service + response

Our customer focused aftermarket organisation is positioned to provide comprehensive care for our varied and diverse product lines. Heritage and obsolete products benefit from the same level of attention and expertise ensuring that reliability and availability is maximised irrespective of a pump's length of service.

GENUINE HIGH QUALITY

Original or upgraded specification spare parts, coupled with full engineering design capability, enables longevity of reliable operation. Highly skilled and experienced service engineers ensure accuracy in build and optimised performance. The worldwide presence of ClydeUnion Pumps offers local service facilities in over 40 countries.

SERVICE SOLUTIONS

ClydeUnion Pumps is committed to supporting our installed base wherever it may be. Depending on your location we will provide either direct service support or support via our local authorised service partners. Whichever option is provided, you can be assured of the best attention from fully qualified and experienced engineers.

- Upgrades + re-rates
- Service + overhaul
- Installation + commissioning
- Technical support
- Inventory management
- 3rd party equipment

Parts + maintenance:
Any brand, any material, anytime. Heritage products, upgrades + improvements

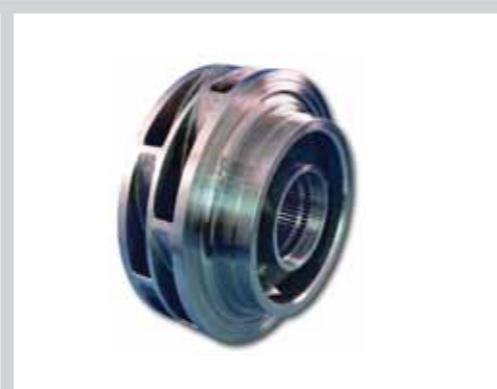

Reciprocating Pumps

HEAVY DUTY, HORIZONTAL, SIMPLEX,
DUPLEX, TRIPLEX, QUINTUPLEX,
API 674 LATEST EDITION



Global locations

EUROPE

Annecy	P: +(33) 45 005 5600	F: +(33) 45 005 5880	E: cu.annecy@spx.com
Glasgow	P: +(44) 141 637 7141	F: +(44) 141 633 2399	E: cu.glasgow@spx.com
Milan	P: +(39) 02 64 672 230	F: +(39) 02 64 672 400	E: cu.milan@spx.com
Moscow	P: +(7) 495 967 3453	F: +(7) 495 785 0636	E: cu.moscow@spx.com
Paris	P: +(33) 14 717 1440	F: +(33) 14 717 1412	E: cu.paris@spx.com
Penistone	P: +(44) 122 676 3311	F: +(44) 122 676 6535	E: cu.penistone@spx.com

AMERICAS

Baton Rouge, LA	P: +(1) 225 775 2660	F: +(1) 225 774 7555	E: cu.batonrouge@spx.com
Battle Creek, MI	P: +(1) 269 966 4600	F: +(1) 269 962 5447	E: cu.battlecreek@spx.com
Burlington, ON	P: +(1) 905 315 3800	F: +(1) 905 336 2693	E: cu.burlington@spx.com
Calgary, AB	P: +(1) 403 236 8725	F: +(1) 403 236 7224	E: cu.calgary@spx.com
Los Angeles, CA	P: +(1) 562 622 2380	F: +(1) 562 622 2375	E: cu.downey@spx.com
Houston, TX	P: +(1) 281 372 5040	F: +(1) 281 372 5042	E: cu.houston@spx.com

SOUTH AMERICA

Itapira, SA	P: +(55) 19 3843 9820	F: +(55) 19 3863 3947	E: cu.brasil@spx.com
--------------------	------------------------------	------------------------------	-----------------------------

ASIA

Beijing	P: +(86) 106 598 9500	F: +(86) 106 598 9505	E: cu.beijing@spx.com
Indonesia	P: +(62) 21 753 5559	F: +(62) 21 753 6031	E: cu.indonesia@spx.com
New Delhi	P: +(91) 120 4640 400	F: +(91) 120 4640 401	E: cu.newdelhi@spx.com
Shanghai	P: +(86) 216 160 6966	F: +(86) 216 160 6968	E: cu.shanghai@spx.com
Singapore	P: +(65) 62 76 7117	F: +(65) 62 78 7117	E: cu.singapore@spx.com

MIDDLE EAST/AFRICA

Abu Dhabi	P: +(971) 2 659 1480	F: +(971) 2 659 1481	E: cu.uae@spx.com
Algeria	P: +(213) 21 69 2319	F: +(213) 21 60 3046	E: cu.algeria@spx.com
Angola	P: +(244) 923 516 224	F: +(1) 281 445 4061	E: cu.angola@spx.com
Dubai	P: +(971) 4 880 7755	F: +(971) 4 886 1133	E: cu.uae@spx.com

CLYDEUNION PUMPS, AN SPX BRAND

149 Newlands Road, Cathcart, Glasgow, G44 4EX, United Kingdom

P: +44 (0)141 637 7141

F: +44 (0)141 633 2399

E: cu.sales@spx.com

SPX reserves the right to incorporate our latest design and material changes without notice or obligation.

Design features, materials of construction and dimensional data, as described in this bulletin, are provided for your information only and should not be relied upon unless confirmed in writing. Please contact your local sales representative for product availability in your region. For more information visit www.spx.com.

The green ">" is a trademark of SPX Corporation, Inc.

CUP-03-RECIP-UK

COPYRIGHT © 2012 SPX Corporation